

TYTAN

DISC MOWER



Operator's Manual

MH-2

MH-3

MH-5

MH-7

• Disc Mowers include Canvas

INSTRUCTIONS FOR PRODUCT DELIVERY

According to the product liability, please check the above mentioned items.

Please check.

- Check machine according to delivery note and remove all packing material. Make sure all safety equipment, PTO shaft and operating devices are at hand.
 - Implement operation and/or maintenance of machine according to the operating instructions.
 - Check tyre pressure.
 - Check wheel nuts tightening.
 - Adjusting PTO shaft to the correct lengths.
 - Adjusting power-take-off speed to the indicated value.
 - Attaching implement to the rear output of the tractor.
 - Trial run the rear output of the tractor and make sure no problem.
 - Validating function during trial run.
 - Pivoting in transporting and operating position explained.
 - Information given re-optional extras.
 - Reading the operating manual is very important.
-

TABLE OF CONTENTS

Table of contents

WARNING SIGNS		TECHNICAL DATA	
Meaning of warning signs	1	Technical data	13
ATTACHING TO TRACTOR		The defined use of the mower unit	13
Attaching implement to tractor	2	Optional equipment:	13
DISMOUNTING IMPLEMENT FROM TRACTOR		Necessary connections	13
Dismounting implement from tractor	3	Position of Vehicle Identification Plate.....	13
Parking in the open	3		
TRANSPORT POSITION		Recommendations for work safety	
Transport position	4	14
Road Transport	4	Driveshaft	17
WORKING POSITION		FETT	19
Working position	5	Assembly	
Changing to working position	5	Gearbox assembly.....	22
STARTING WORK		Mowing disk assembly.....	24
Important points before starting work	6	Safety guard assembly.....	27
Safety hints	6	Three point mounted.....	30
Turning maneuver when mowing	7		
Take care when turning on slopes!	7		
MOWING			
Mowing	8		
General Guidelines when Working with Implement	8		
Collision safety device	8		
MAINTENANCE			
Safety point	9		
General maintenance hints	9		
Cleaning of machine parts	9		
Parking in the open	9		
Winter storage	9		
Drive shafts	10		
Hydraulic unit	10		
gear box oil level check	10		
Cut bar oil change	11		
V-belt Drive	12		
Checking wear on mowing blade holders ..	12		

Meaning of warning signs



Warning!

Read and understand the operator manual completely before operating your rotary hoe.



Caution!

Keep hand, feet, hair and clothing away from all moving parts.



Caution!

Keep all bystanders a safe distance away from machine and tractor.

Attaching implement to tractor

1. Horizontally set lifting gear's lower link

2. Attach implement to three-point linkage.

- Attach mower unit so that gap between inner cutting discs and tractor tires is **0 - 10 cm**.

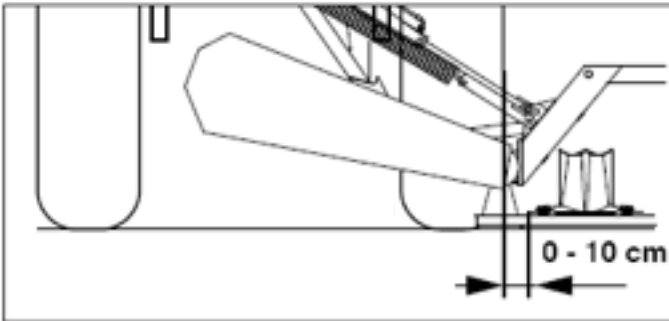

- Insert lower link pins (1) into supporting frame according to three-point category and track width.

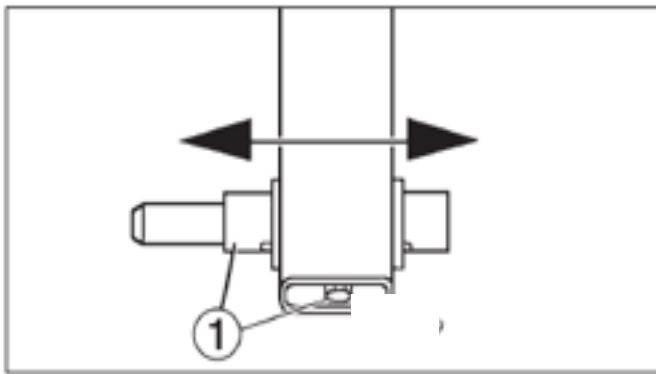

- with dual wheels or particularly wide tires, see notes in the supplement of this operating manual.

3. Connect hydraulic snap-connector (60)

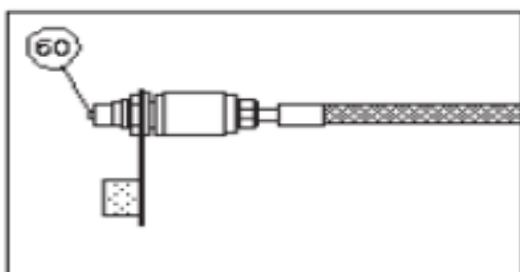

4. Set upper link spindle

- By turning upper link spindle (16) cutter is brought into a horizontal or a slightly forward inclined position.

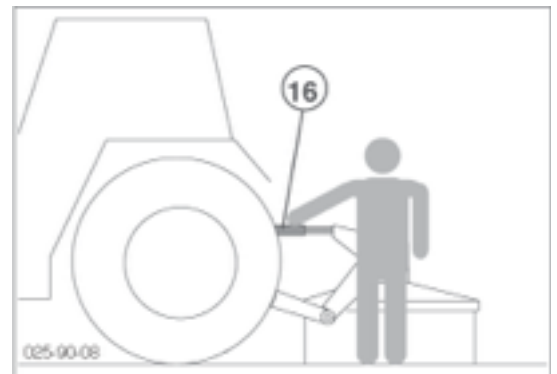

5. Secure lower link (4) against sideways movement.

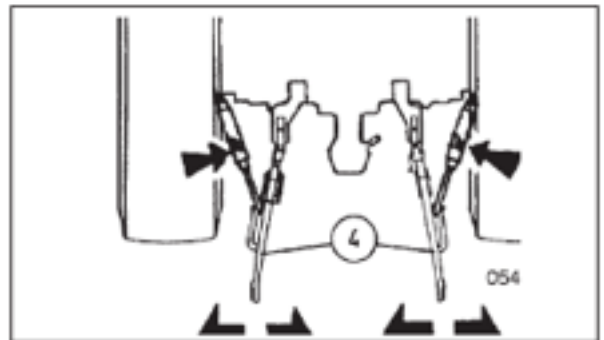

★ In the process of connection, when the tractor is moving, if there is people between the tractor and working machine, it may cause injury accident. Be sure no people stand between the tractor and working machine during the tractor moving.

DISMOUNTING IMPLMENT FORM TRACTOR

Dismounting implement from tractor



1. Lower cutter bar hydraulically to the ground. Safety note!

- actuate servo-valve (ST)

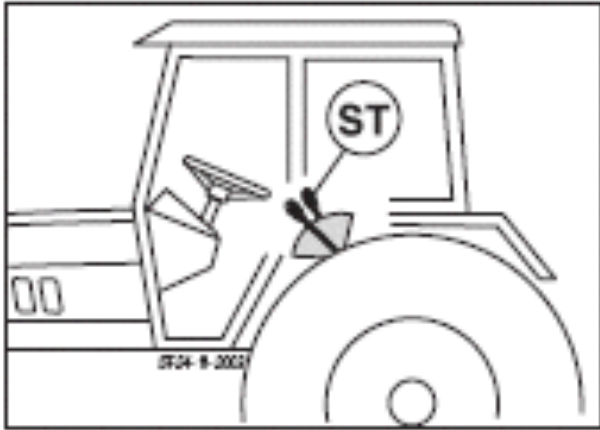

Before dismounting, check the locking device properly, otherwise danger of tipping!

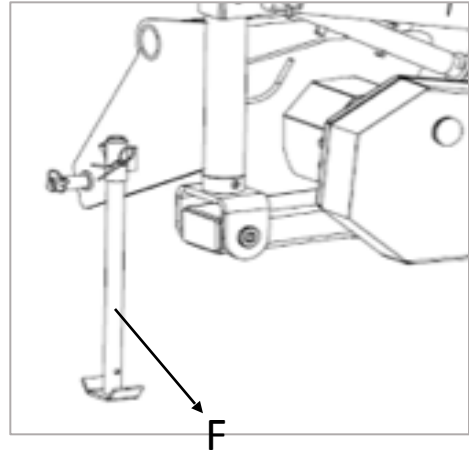

5. Dismount implement from tractor

- disconnect hydraulic lines
- disconnect upper link
- disconnect lower link
- disconnect drive shaft and lay it down (GW)

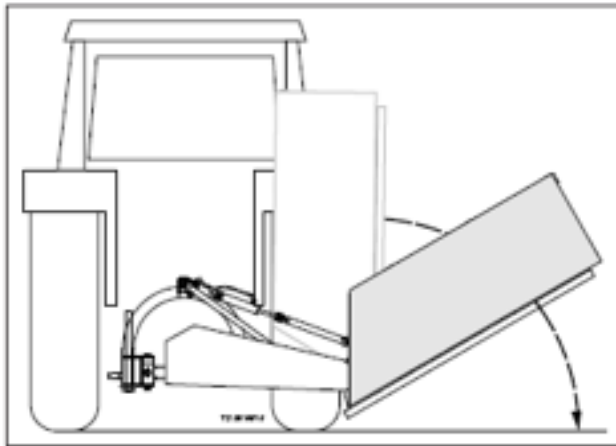

Parking in the open

When parking in the open for long periods of time, clean plunger rods and then coat with grease.

2. Swing support stand down and secure (F)

3. Lower implement to the ground using lifting gear.



Note

A rusty plunger rod can damage cylinder's sealing elements.

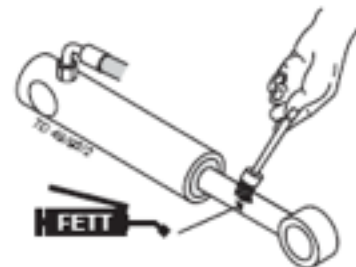

★ At season's end

- clean plunger rod and all other shiny parts, then grease them.
- pay attention to the hints in chapter "MAINTENANCE"

TRANSPORT POSITION

Transport position

Safety Precaution!

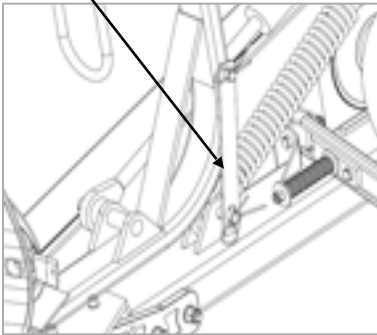
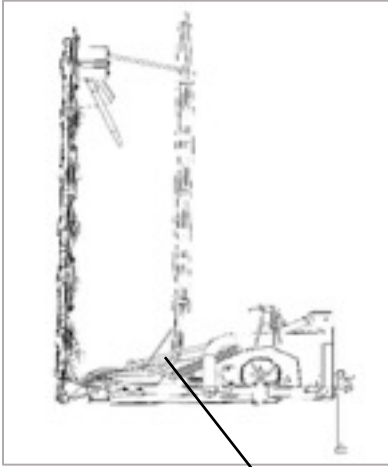

Road Transport

- Observe the regulations issued by your country's legislative body.
- Travelling on public roads may only be undertaken as is described in the chapter "Transporting Position".
- Fasten lower hydraulic link so that implement cannot swing out sideways.

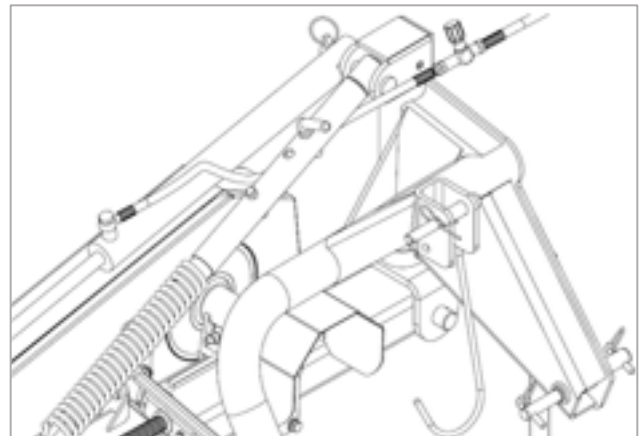
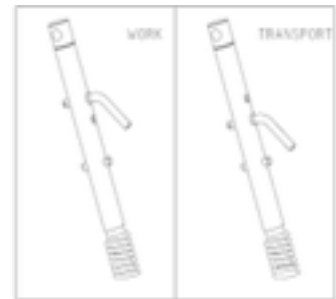
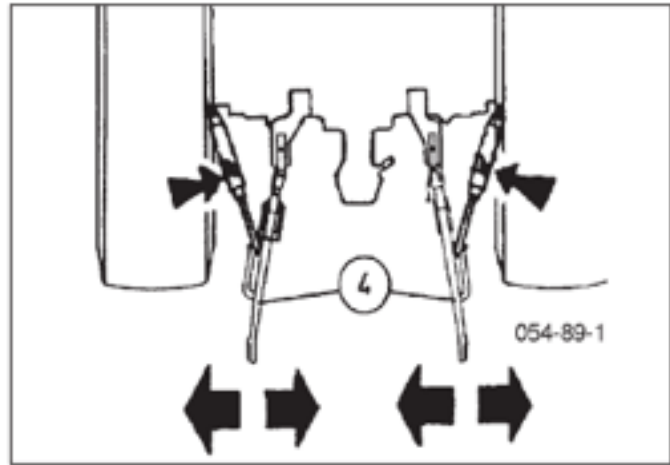

Changing from working position to transport position is only to be carried out on even, firm ground.

Never let the mowing mechanism run with the mower raised.

- Before you leave the tractor, lower the machine onto the ground!

WORKING POSITION

Working position



Safety Precaution!

Changing from transport position to working position is only to be carried out on even, firm ground.

Make sure that swivel area is free and that nobody is standing in the danger area.



Starting position for lowering the cutter bar

1. Implement is attached to tractor
- see chapter "Attaching implement to tractor"
2. Cutter bar in transport position
3. Support stand swung up and secured



Changing to working position

1. Lower cutter bar hydraulically to the ground.

- Move hydraulic control valve (ST) to the "LOWER" position(S)

2. Set height of lifting gear (H1)

This lifting gear position (H1=400-420mm) does not need to be changed when mowing or turning Using the tractor's lifting gear, raise or lower the implement until a gap of about is achieved.

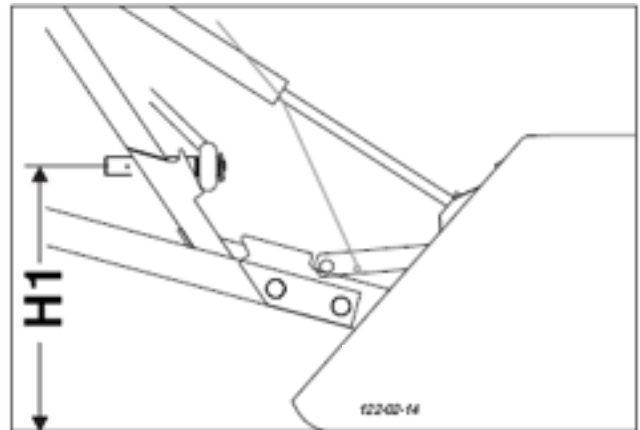

3. Close front protection covers (5a)

• Operation only with closed protection covers.

Important points before starting work



After the first hours of operation

- Retighten all knife screw fittings.

Safety hints

1. Check

- Check the condition of knives and the knife holder.
- Check cutting drums for damage (see also chapter "Maintenance").

2. Switch-on the machine only in working position and do not exceed the prescribed power take-off speed (for example max. 540 rpm).

A transfer, which is located near the gear, advises which PTO speed your mower unit is equip

540 Upm

1000 Upm

- Turn the PTO on only when all safety devices (coverings, protective aprons, casings, etc.) are in proper condition and attached to the implement in the correct protective positions.

3. Pay attention to correct PTO direction of rotation!



4. Damage protection!

- The surface to be mowed must be free of obstructions or foreign objects. Such objects (e.g. large stones, pieces of wood, boundary stones, etc.) can damage the mower unit.

In the event of a collision

- Stop immediately and switch off the drive.
- Carefully check the implement for damage. The mowing discs and their drive shaft must be checked in particular .
- Have the implement checked also by a specialist workshop if necessary.

After any contact with foreign objects

- Check the condition of knives and the knife holder.
- Retighten all knife screw fittings.

5. Stay clear while engine is running.

- Keep people out of the danger zone - foreign bodies which can be ejected by the mower could injure them.

Special care is necessary on or near stony ground.



6. Wear hearing protection

The noise level in the workplace can deviate from the measured value (see Technical Data) partly because of the differing cabin types of various tractors.



Turning maneuver when mowing

- The cutter bar can be raised hydraulically (22°).
- The drive must not be turned off to do this.
 - The lifting gear's (H1) position does not need to be altered when turning.

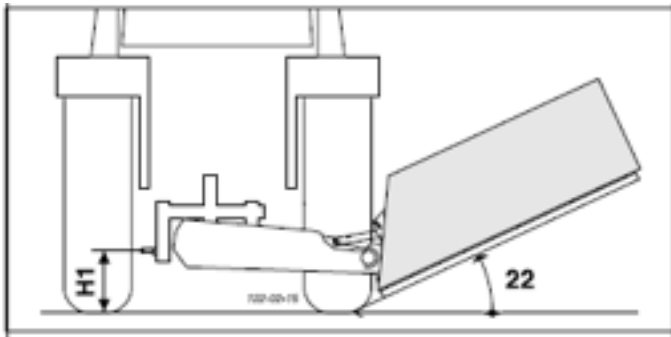

Safety advice

- Reduce speed in left-hand curves accordingly.
- Travel so that the raised mower unit is facing uphill.
- It is better to travel in reverse on a slope than to carry out a risky turning maneuver.

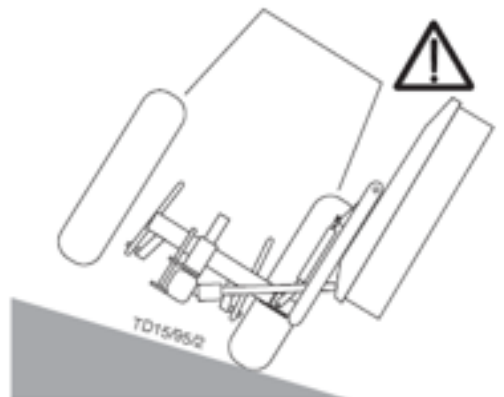
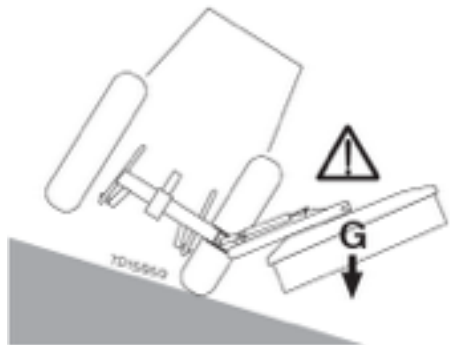
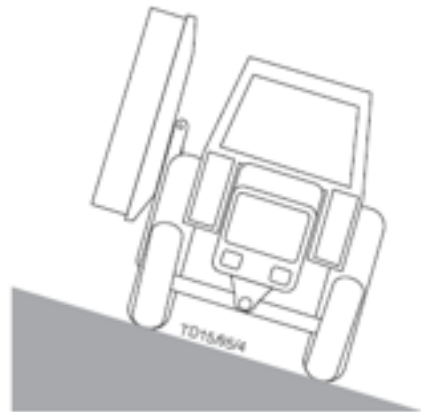

- 
- Attention!**
Do not enter the mower unit area as long as the drive is running.

Take care when turning on slopes!



The tractor's travelling characteristics are influenced by the weight (G) of the mower unit. This can lead to dangerous situations, especially on slopes.

Danger of tipping occurs

- when the mower unit is facing downhill and in a raised position,
- when travelling in a left-hand curve with the mower unit raised,
- when travelling in a left-hand curve in the transport position (mower unit completely raised).

Mowing



- 1. Horizontally set lifting gear's lower link (Sp)**
- 2. Adjust cutting height by turning upper link spindle (16)**

- cutter disc inclination: max. 5°

- 3. Before mowing, throw-in PTO slowly outside crop and bring mower drums up to full speed.**

Noises conditional to PTO free-wheel system can be prevented through an even continuous increase in rpm.

- Travelling speed is set according to ground conditions and crop.

- 4. Hydraulic control valve (ST)**

- Single action hydraulic control valve (ST) to "LOWER"

- Double-action hydraulic control valve (ST) to "FLOATPOSITION"

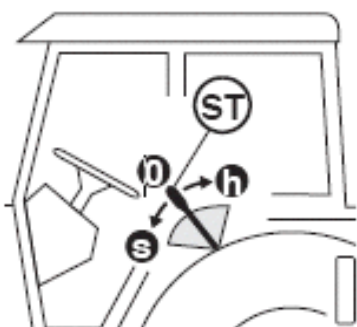

General Guidelines when Working with Implement

- The mower unit is suitable for gradients of between +90° and -30°.

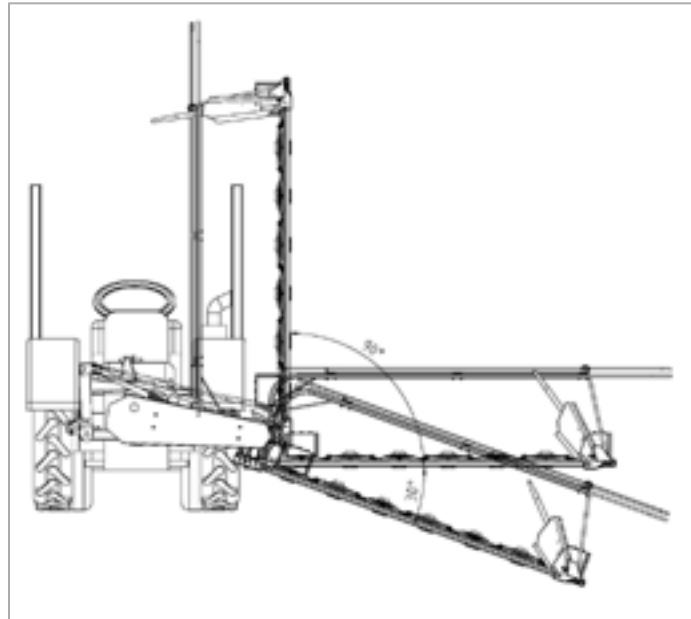

Collision Safety Device

When mowing around trees, fences, boundary stones etc., collisions between the cutter bar and obstacles can occur despite careful and slow driving. Therefore, in order to prevent such damage, collision protection has been planned for the cutting device.

Safety point

- Turn engine off when adjustment, service and repair work is to be done.

General maintenance hints

In order to keep the implement in good condition after long periods of operation, please observe the following points:

- Tighten all screws after the first hours of operation.

In particular check:

- blade screws on the mowers
- tine screws on the swather and tedder.

Spare part

a. The **original components and accessories** have been designed especially for these machines and appliances.

b. We want to make it quite clear that components and accessories that have not been supplied by us have not been tested by us.

c. The installation and/or use of such products can, therefore, negatively change or influence the construction characteristics of the appliance. We are not liable for damages caused by the use of components and accessories that have not been supplied by us.

d. Alterations and the use of auxiliary parts that are not permitted by the manufacturer render all liability invalid.

Cleaning of machine parts

Attention!

Do not use high-pressure washers for the cleaning of bearing- and hydraulic parts.

- Danger of rust!
- After cleaning, grease the machine according to the lubrication chart and carry out a short test run.
- Cleaning with too high pressure may do damage to varnish.



Parking in the open

When parking in the open for long periods of time, clean piston rods and then coat with grease.

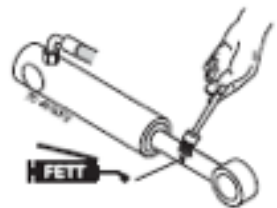

Winter storage

- Thoroughly clean machine before storage.
- Put up protection against weather.
- Change or replenish gear oil.
- Protect exposed parts from rust.
- Lubricate all greasing points according to lubrication chart.

Drive shafts

- see notes in the supplement

For maintenance please note!

The instructions in this operating manual are always valid.

In case there are no special instructions available, then the notes in the accompanying drive shaft manufacturer's instructions are valid.

Hydraulic unit

Caution! Danger of injury or infection!

Under high pressure, escaping fluids can penetrate the skin. Therefore seek immediate medical help!

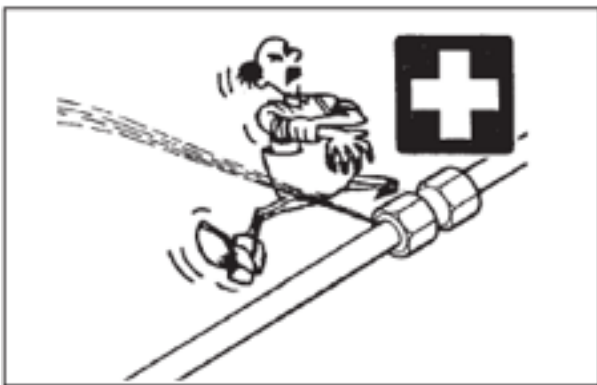

Make sure that the hydraulic system is suitable for the tractor before connecting the hydraulic lines.

After the first 10 operating hours and then every consecutive 50 operating hours

- Check the hydraulic unit and lines for tightness and retighten screw connections if necessary.

Before operation

- Check hydraulic hoses for wear.

Replace worn or damaged hydraulic hoses immediately.

The replacement hoses must meet the manufacturer's technical requirements. Hose lines are subject to natural ageing. The period of use should not exceed 5 – 6 years.



Safety points!

- Turn engine off when adjustment, service and repair work is to be done.
- Do not work under the machine without safe support.
- Retighten all screws after the first hours of operation.
- Only place the machine on an even, firm ground.
- Clean the hydraulic line couplings and the oil connections each time before coupling.
- Check for chafing and jamming points.

Gear box oil level check

- Change oil after the first 50 operating hours. Under normal operating conditions, oil is to be replenished annually (OIL LEVEL).

- Change oil after 300 ha at the latest.

Value: 0.5L. SAE 90 GL-5

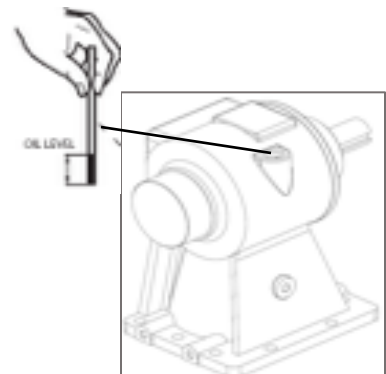

Cut bar oil change

1. Raise cutter bar and bring into vertical position

* See transport position

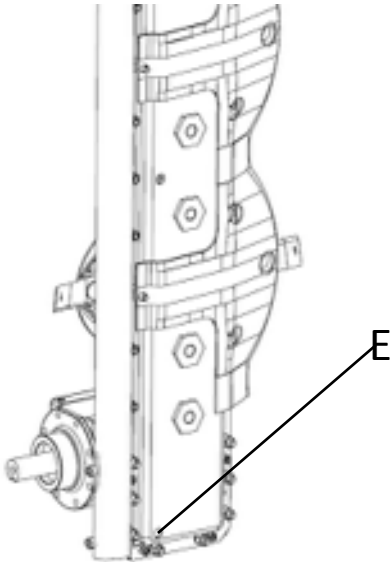

Quantity: 0.5L. SAE 90 GL-5

F.DM170: 2L

F.DM210: 2.5L

F.DM250: 3L

F.DM290: 3.5L

7.Oil change time

Gear box :300 hour

Cut bar :300 hour

Lubricating: Before use

V-belt Drive

- check V-belt tension after 1 hour, after 5 hours, after 20 hours, then as necessary Setting range:

0.5 – 3 mm

- Re-tension is only necessary when the setting becomes more than 3 mm.
- If one of the 4 V-belts is damaged or stretched, then all 4 V-belts should be exchanged

IMPORTANT!

If the V-belts are tensioned too taut, the danger exists of the bearing and shafts becoming damaged.

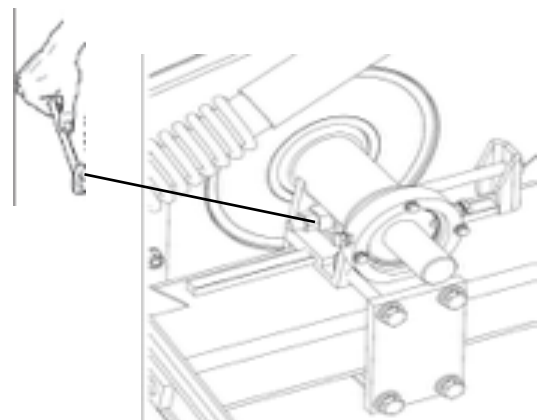

2. Place suitable container underneath

3. Remove hexagonal screw (E) completely and drain old oil into container

- Dispose of old oil properly

4. Lower cutter bar and bring into horizontal position

* See working position

5. Close the drain outlet with the hexagonal screw (E)

6. Fill with oil



- Too much oil leads to gear overheating during operation

- Too little oil will not guarantee the necessary lubrication

Checking wear on mowing blade holders

Process of visual control:

1. remove mowing blades
2. remove grass and dirt

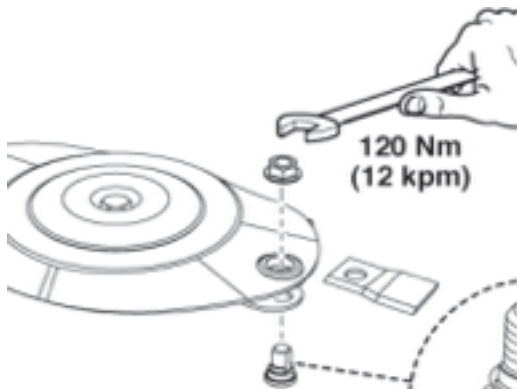

Attention!

Danger of accident if wearing parts are worn. If such wearing parts are worn out they must not be used any longer.

Otherwise accidents may be caused through parts that are fringed away (e.g. mowing blades, fragments...)



If you notice one or several of these characteristics of wear stop mowing at once!

Worn parts must be replaced by original parts made by Distributor immediately !

Screw down the pin of the blade with the nut with 120 Nm.



Check the suspension of mowing blades as to wear and other damage:

- every time before bringing the machine into operational use
- several times during use
- immediately after hitting an obstacle (e.g. a stone, piece of wood, metal,...)

Technical data

	F.DM170	F.DM210	F.DM250	F.DM290
Three-point linkage	Kat. I.II	Kat. I.II	Kat. I.II	Kat. II
Working width	1.6 m	2.0 m	2.4m	2,8 m
No. of mowing discs	4	5	6	7
No. of knives per disc	2	2	2	2
Max. PTO speed	540 RPM	540 RPM	540 RPM	540 RPM
Weight	Min.370kg	min. 420 kg	min. 535 kg	min. 565 kg
Required power	18-30kw 25-40HP	26-37KW 35-50HP	33-44KW 45-60HP	36-60KW 50-80HP

The defined use of the mower unit

mower is intended solely for normal use in agricultural work.

- The mowing of grassland and short stemmed fodder.

Any other uses outside of these are regarded as undefined.

The manufacturer takes no responsibility for any resulting damage which occurs henceforth. The risk is carried by the user alone.

- The keeping of operating, service and maintenance requirements laid down by the manufacturer also come under the heading of defined use“.

Optional equipment:

- Warning signs with lighting
- Swath discs
- Flat cone conveyors
- Wearing runners
- High cut runners

Necessary connections

- 1 x single action hydraulic connection (minimum necessary tractor fitting)

Operating pressure min : 80 bar

Operating pressure max: 180 bar.

Position of Vehicle Identification Plate

The chassis number is engraved on the name plate illustrated on the

left. Warranty claims, enquiries and spare parts orders cannot be made without quoting the chassis number.

Please enter the number on the title page of the Operating Instructions immediately on taking delivery of the vehicle/equipment.



Recommendations for work safety

All points referring to safety in this manual are indicated by this sign.

1. Operating instructions

- a. The operating instructions are important for the correct operation of the machine. Make sure that the operating instructions are always on hand when operating the machine.
- b. Keep the operating instructions as long as the machine is in your hands.
- c. Pass the operating instructions on to the buyer when selling the machine.
- d. Make sure that all safety and warning symbols remain attached on the machine and keep them readable. The hazard warnings provide important information for a safe operation and, thus, your safety.

2. Qualified personnel

- a. Only persons of legal age, mentally and physically able and having been trained or familiarized accordingly must operate this machine.
- b. Persons not yet trained or familiarized or under training must only operate this machine under the supervision of an experienced person.
- c. Inspection, setting and repair work must only be performed by authorized persons.

3. Repair work

- a. These instructions only refer to service, maintenance and repair operations the user is able to carry out without assistance. Any work beyond this scope has to be carried out at authorized workshops only.
- b. Repairs on the electrical and hydraulic system, preloaded springs, pressure accumulators, etc. require sufficient knowledge, correct tools and protective clothing and, thus, must only be performed at authorized workshops.

4.) Defined use

- a. See "Technical Data".
- b. The keeping of operating, service and maintenance requirements laid down by the manufacturer also come under the heading of "defined use".

5.) Spare parts

- a. The **original components and accessories** have been designed especially for these machines and appliances.
- b. We want to make it quite clear that components and accessories that have not been supplied by us have not been tested by us.



c. The installation and/or use of such products can therefore, negatively change or influence the Construction characteristics of the appliance. We are not liable for damages caused by the use of components and accessories that have not been supplied by us.

d. Alterations and the use of auxiliary parts that are not permitted by the manufacturer render all liability invalid.

6.) Protection devices

a. All protection devices must remain on the machine and be maintained in proper condition. Punctual replacement of worn and damaged covers is essential.

7.) Before starting work

a. Before commencing work, the operator must be aware of all operating devices and functions. The learning of these is too late after having already commenced operation!

b. The vehicle is to be tested for traffic and operating safety before each operation.

8.) Asbestos

a. Certain sub-supplied components of the vehicle may contain asbestos due to technical reasons. Observe the warning on spare parts.

9.) Transport of persons prohibited

a. The transport of persons on the machine is not permitted.

b. The machine may only be driven on public roads when in the position stipulated for road transport.

10.) Driving ability with auxiliary equipment

a. The towing vehicle is to be sufficiently equipped with weights at the front or at the rear in order to guarantee the steering and braking capacity (a minimum of 20% of the vehicle's tare weight on the front axle).

b. The driving ability is influenced by ground conditions and by the auxiliary equipment. The driving must be adapted to the corresponding terrain and ground conditions.

c. When driving through curves with a connected appliance, observe the radius and swinging mass of the appliance.



d. When travelling in a curve with attached or semi mounted implements, take into account the working range and swing mass of the implement!

11.) General

a. Before attaching implement to three-point linkage, move system lever into a position whereby unintentional raising or lowering is ruled out!

b. Danger of injury exists when coupling implement to tractor!

c. Danger of injury through crushing and cutting exists in the three-point linkage area!

d. Do not stand between tractor and implement when using three-point linkage external operation!

e. Attach and detach drive shaft only when motor has stopped.

f. When transporting with raised implement, secure operating lever against lowering!

g. Before leaving tractor, lower attached implement to the ground and remove ignition key!

h. Nobody is to stand between tractor and implement without tractor being secured against rolling using parking brake and/or wheel chocks!

i. For all maintenance, service and modification work, turn driving motor off and remove universal drive.

12.) Cleaning the machine

a. Do not use high-pressure washers for the cleaning of bearing- and hydraulic parts.

Matching driveshaft to tractor

To determine the actual length required, hold the two halves of the driveshaft side by side.

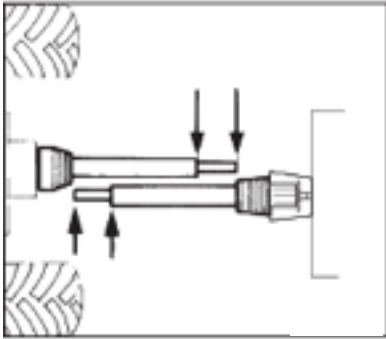

Procedure for cutting to length

- To determine length required, set implement in closest working position (L2) to tractor, hold driveshaft halves side by side and mark off.

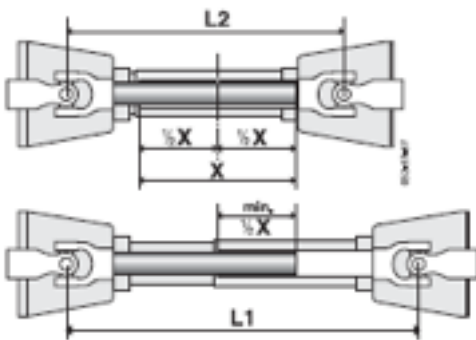

Important!

- Note the maximum operating length (L1)
- Try to attain the greatest possible shaft overlap (min. $1/2 X$)!
- Shorten inside and outside tube guard by the same amount.
- Fit torque limiter (2) of drive shaft to implement end of driveshaft!

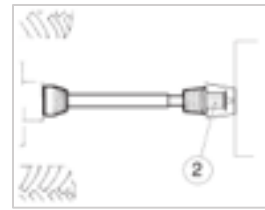

- Always check that drive shaft locks are securely engaged before starting work.

Retaining chain

- Use chain to prevent tube guard from rotating. Take care that chain does not impede driveshaft pivoting.

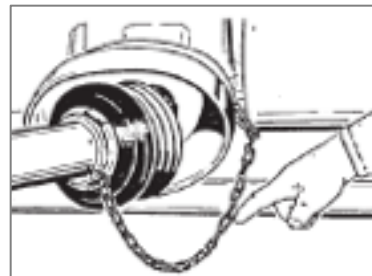

Rules for working

Never exceed the maximum p. t. o. speed when using the implement.

- When the PTO is switched off, the implement hitched up may not stop at once. Do not go close to the implement until all motion has stopped; only then may work be done on it.
- When the implement is parked, either remove the driveshaft and store it, or secure it with a chain. Do not use retaining chain (H) for this.

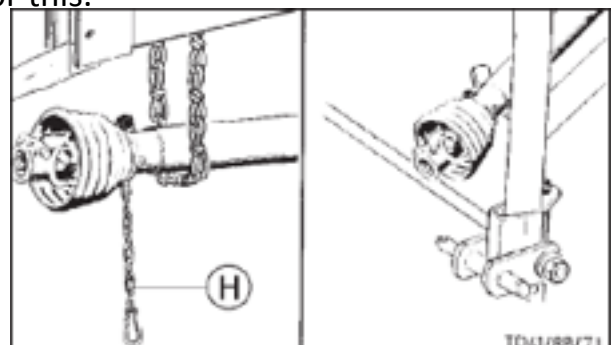

Wide-angle joint:

Maximum angle of deflection when working/ stationary : 70°

Standard joint :

Maximum angle of deflection when stationary: 90°

Maximum angle of deflection when working: 35°

Maintenance

Replace worn-out covers/guards at once.

- Lubricate with a brand-name grease before starting work and every 8 hours worked.

- Before any extended period of non-use, clean and lubricate driveshaft.

For winter working, grease the tube guards, to avoid them freezing together.

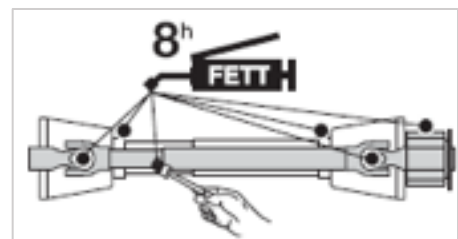
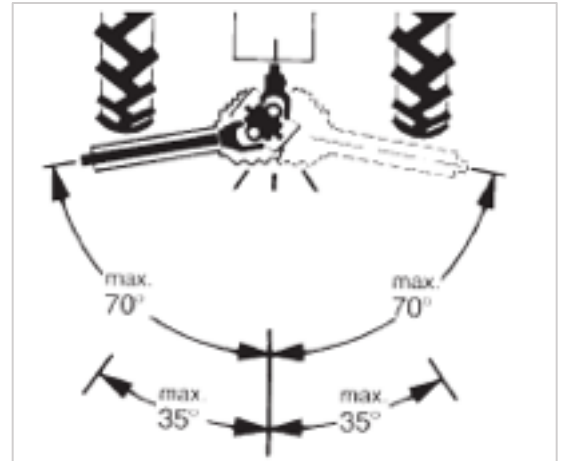

How a cam type cut out safety clutch works

This overload clutch switches the torque transmitted to zero if overloaded. To revert to normal operation, stop the PTO drive briefly. The clutch reengages at a speed below 200 rpm.

IMPORTANT!

Re-engaging is also possible by decreasing the PTO rpm.

TAKE NOTE!

The overload clutch on the driveshaft is not a "Full up" indicator. It is purely a torque limiter designed to protect the implement against damage.

Driving the right way will avoid triggering the clutch too often, and thus causing unnecessary wear on it and the implement.

Lubricating interval: 500 hrs. (Special lubricant)

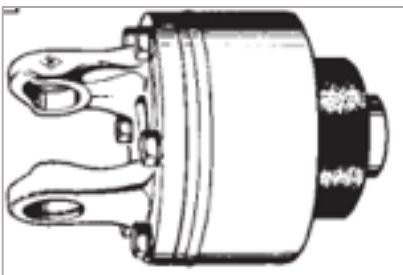

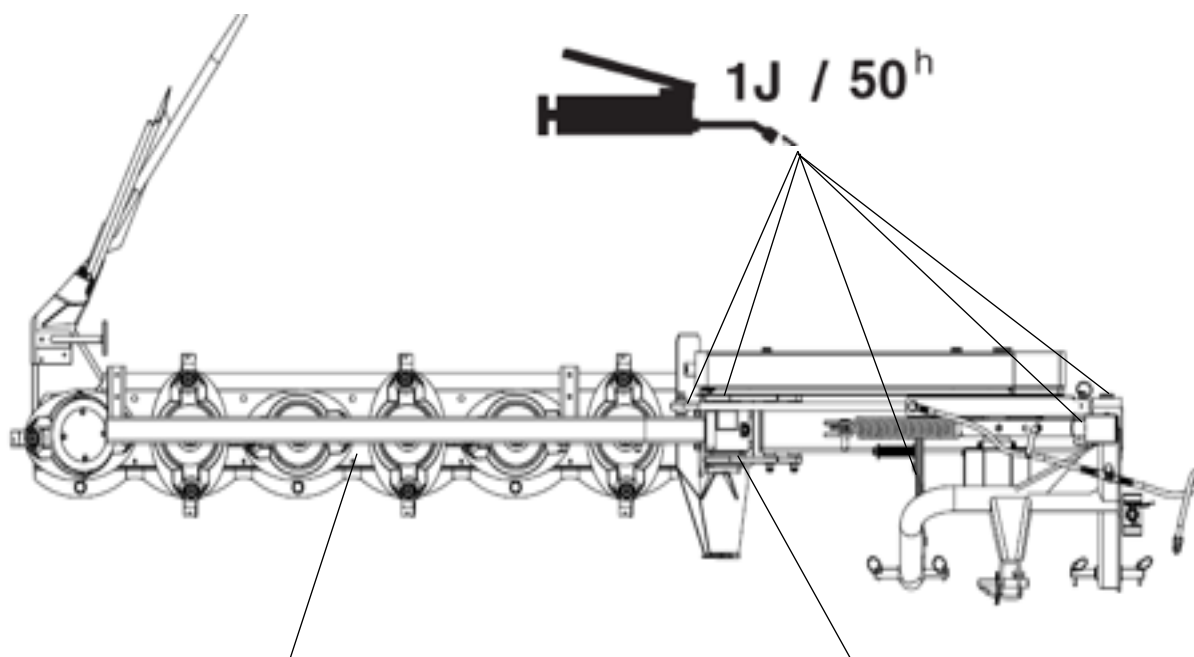

MH-2: 2L SAE 90 GL-5

MH-3: 2.5L SAE 90 GL-5

MH-5: 3L SAE 90 GL-5

MH-7: 3.5L SAE 90 GL-5

0.5L. SAE 90 GL-5

IMPORTANT! ADDITIONAL INFORMATION

Combination of tractor and mounted implement



The mounting of implements on the front or rear three point linkage shall not result in exceeding the maximum permissible weight, the permissible axle loads and the tyre load carrying capacities to the tractor. The front axle of the tractor must always to be loaded with at least 20 % of the unladen weight of the tractor.

Make sure before buying an implement that these conditions are fulfilled by carrying out the following calculations or by weighing the tractor/implement combination.

Determination of the total weight, the axle loads, the tyre load carrying capacity and the necessary minimum ballasting

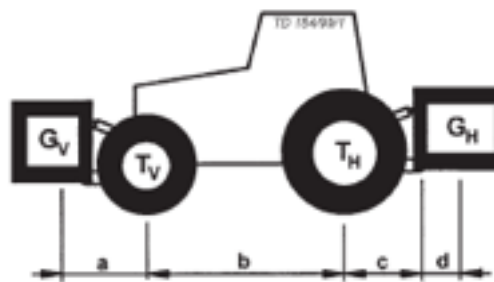

For the calculation you need the following data:

T_t [kg]	unladen weight of tractor	①	a [m]	distance from centre of gravity for combined front mounted implement/front ballast to front axle centre	② ③
T_v [kg]	front axle load of unladen tractor	①			
T_H [kg]	rear axle load of unladen tractor	①	b [m]	Tractor wheelbase	① ③
G_H [kg]	combined weight of rear mounted implement/rear ballast	②	c [m]	distance from rear axle centre to centre of lower link balls	① ③
G_v [kg]	combined weight of front mounted implement/front ballast	②	d [m]	distance from centre of lower link balls to centre of gravity for combined rear mounted implement/rear ballast	②

- ① see instruction handbook of the tractor
- ② see price list and/or instruction handbook of the implement
- ③ to be measured

IMPORTANT! ADDITIONAL INFORMATION

Consideration of rear mounted implement and front/rear combinations

1. CALCULATION OF MINIMUM BALLASTING AT THE FRONT $G_{V \min}$

Record the calculated minimum ballasting which is needed at the front of the tractor into the table.

$$G_{V \min} = \frac{G_H \cdot (c+d) - T_V \cdot b + 0,2 \cdot T_L \cdot b}{a+b}$$

Front mounted implement

2. CALCULATION OF THE MINIMUM $G_H \min$

$$G_H \min = \frac{G_V \cdot a - T_H \cdot b + 0,45 \cdot T_L \cdot b}{b+c+d}$$

Record the calculated minimum ballasting which is needed at the rear of the tractor into the table.

3. CALCULATION OF THE REAL FRONT AXLE LOAD $T_V \text{tat}$

(If with the front mounted implement (G_V) the required minimum front ballasting ($G_V \min$) cannot be reached, the weight of the front mounted implement has to be increased to the weight of the minimum ballasting at the front!)

$$T_V \text{tat} = \frac{G_V \cdot (a+b) + T_V \cdot b - G_H \cdot (c+d)}{b}$$

Record the calculated real front axle load and the permissible front axle load of the tractor into the table.

4. CALCULATION OF THE REAL TOTAL WEIGHT G_{tat}

(If with the rear mounted implement (G_H) the required minimum rear ballasting ($G_H \min$) cannot be reached, the weight of the rear mounted implements has to be increased to at least the weight of the minimum ballasting at the rear!)

$$G_{\text{tat}} = G_V + T_L + G_H$$

5. CALCULATION OF THE REAL REAR AXLE LOAD $T_H \text{tat}$

Record the calculated real and the permissible rear axle load given in the instruction handbook for the tractor into the table.

6. TYRE LOAD CARRYING CAPACITY $T_H \text{tat} = G_{\text{tat}} - T_V \text{tat}$

Record double the value (two tyres) of the permissible load carrying capacity into the table (see for instance documentation provided by the tyre manufacturer).

Gearbox assembly

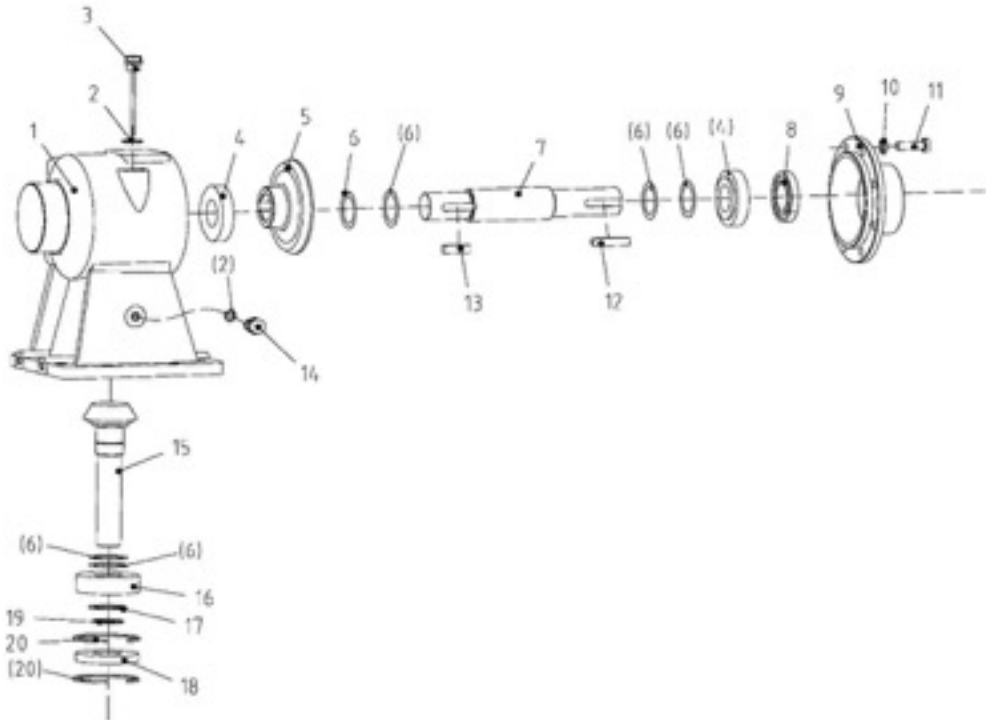

NO.	Code	Designation	Material Code	Qty
1	DM170.104	Gearbox	11012900044	1
2	M16	Combined sealing gaskets 16	11011200009	2
3	DM170.045	Oil scale assembly	11000200449	1
4	GB/T 297-1994	Tapered roller bearing 30207	11011500048	2
5	DM170.108	Driving bevel gear	11010100018	1
6	DM170.107	Shaft washer	11000100124	6
7	NDM215.203	Big gear shaft	11012700042	1
8	TC35*65*12	Oil seal 35*65*12	11011200022	1
9	DM170.105	Gearbox cover	11012900043	1
10	GB/T 93-1987	Spring washer 10	14020000007	4

NO.	Code	Designation	Material Code	Qty
11	GB/T 5783-2000	Bolt M10*25	14010100039	4
12	GB/T 1096-2003	Flat key grade C 10*8*50	14030200000	1
13	GB/T 1096-2003	Flat key grade A 10*8*35	14030000005	1
14	M16*1.5 (JYG-82)	Vent-plug M16*1.5	11010600010	1
15	DM170.111	Driven bevel gear shaft	11010100019	1
16	GB/T 276-94	Deep groove ball bearing	11011500035	1
17	DM170.112	Gear shaft washer	11000100126	1
18	'TC35*80*8	Oil seal 35*80*8	11011200024	1
19	GB/T 894.2-86	Circlip 35	14000300025	1
20	GB/T 893.1-86	circlip 80	14000400049	2

Mowing Disk Assembly

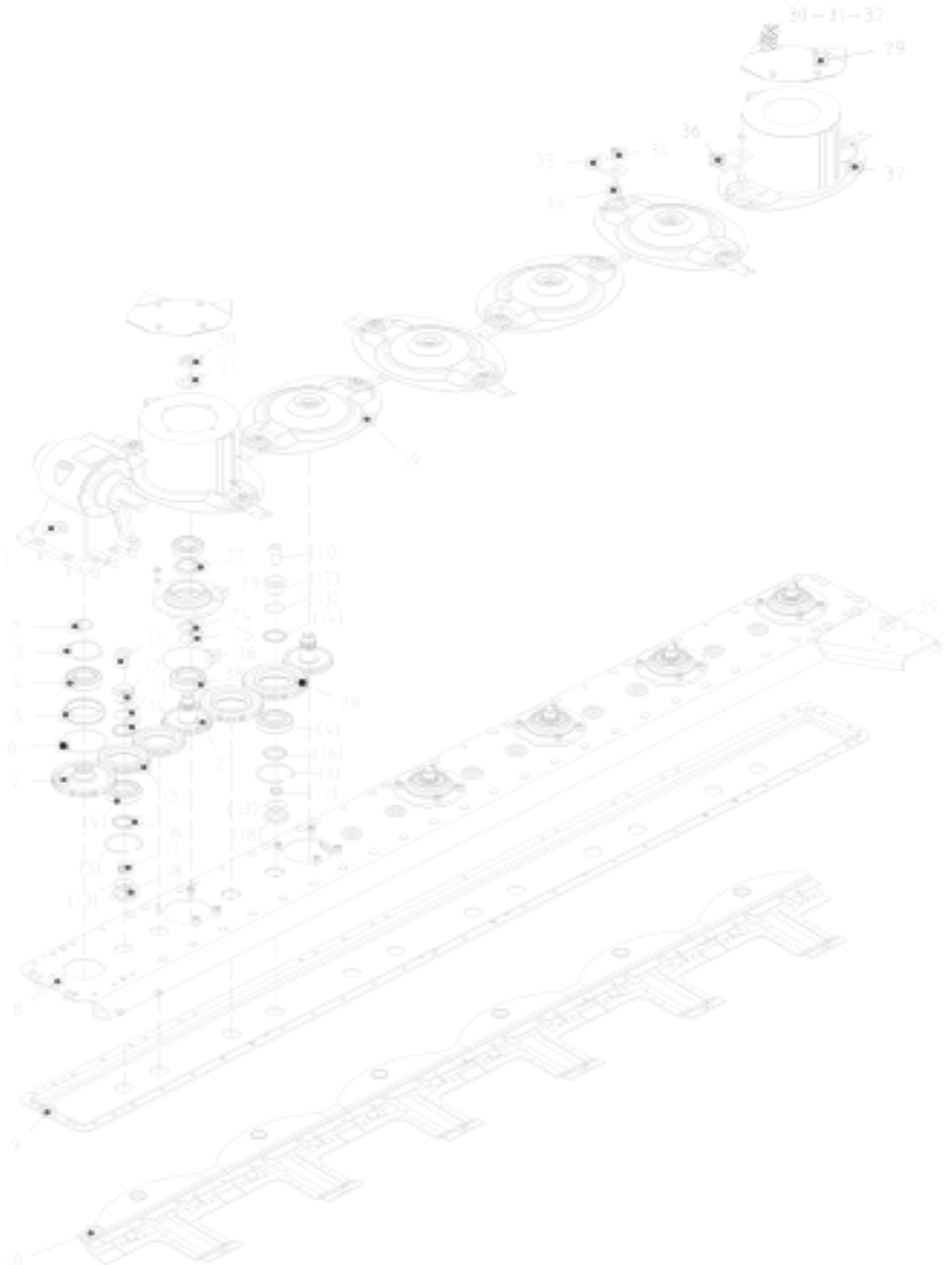

NO.	Code	Designation	Material Code	Qty			
				Model I 170	Model 210	Model 250	Model I 290
1	DM170.019	Gearbox assembly	11000200938	1			
2	GB/T 894.2-1986	Circlip 40	14000300028	1			
3	GB/T 893.1-1986	Circlip 80	14000400049	9	9	13	11
4	GB/T 276-1994	Deep groove ball bear 6208-C3-Z2	11011500026	8	9	13	9
5	DM170.136	Bearing holder	11012700016	1			
6		O-ring 105*5	11011200129	1			
7	DM170.125	Spline gear	11010100020	1			
8	KFDM170.050	Upper box weldment	11000201270	1			
	KFDM215.026		11019900008		1		
	KFDM255.026		11000201165			1	
	KFDM285.020		11000201320				1
9	KFDM170.137	Lower box weldment	11000000527	1			
	KFDM215.105		11019900009		1		
	KFDM255.103		11000000455			1	
	KFDM285.201		11000000575				1
10	KFDM170.029	Cover weldment	12000000807	1			
	KFDM215.016		11000200429		1		
	KFDM255.029		11000201168			1	
	KFDM285.014		11000201351				1
11	KFDM215.110	Hexagon socket head cap screwsM20*38	11012700021	8	11	12	17
12	KFDM215.106	Idler shaft sleeve	11000100146	8	11	12	17
13		O-ring 40*1.5	11011200057	16	22	24	34
14	KFDM215.111	Washer 52-40-3.5	11000100151	8	8	12	8
15	KFDM215.101	Mid gear I	11010100026	2	2	2	2
16	KFDM215.110	Washer 52-40-6	11000100150	8	8	12	8
17	KFDM215.104	Nylon swelling link sets	11000100152	8	8	12	17

NO.	Code	Designation	Material Code	Qty			
				Mode I 170	Mode I 210	Mode I 250	Mode I 290
18	KFDM215.107	Special nut for idler	11000100147	8	11	12	17
19	KFDM215.015	Mowing disk weldment	11000200428	3	4	4	5
20	OW-GUK28-White zinc	Round lock nut M25*1.5	14051000001	4	5	6	7
21	GB/T 95-2002	Plain washer 25	14040000016	4	5	6	7
22	TC45*60*7- FKM(brown)	Oil seal 45*65*7	11011200035	4	5	6	7
23	KFDM215.202	Cutter head connecting cover	11012700022	4	5	6	7
24	DM170.132	Gearing holder	11000100129	4	5	6	7
25		O-ring 35*3.1	11011200056	4	5	6	7
26		O-ring 109.6*3.1	11011200060	4	5	6	7
27	DM170.127	Mowing disk gear z34	11010100022	4	5	6	7
28	KFDM215.103	Mid gear III z=45	11010100028	6	6	10	6
29	DM170.152	Disk cover	11000000108	1	1	2	2
30	GB/T 5783-2000	Bolt M8*20	14010100017	4	4	8	8
31	GB/T 93-1987	Spring washer 8	14020000006	4	4	8	8
32	GB/T 95-2002	Flat washer 8	14040000002	4	4	8	8
33	KFDM215.112	Right blade	11010200033	4	5	6	6
34	GB/T 889.1-2000	Lock nut M12	14050100006	8	10	12	14
35	DM170.161	Ball stud M12*16	11012200004	8	10	12	14
36	KFDM215.111	Left blade	11010200032	4	5	6	8
37	KFDM215.017	CMowing disk with cover weldment	11000200430	1	1	2	2
38	GB/T 276-1994	Deep groove ball bearing 6307-2Z	11011500036	4	5	6	7
39	DM255.104	Connecting plate-L	11000000115	1			

Safety Guard Assembly

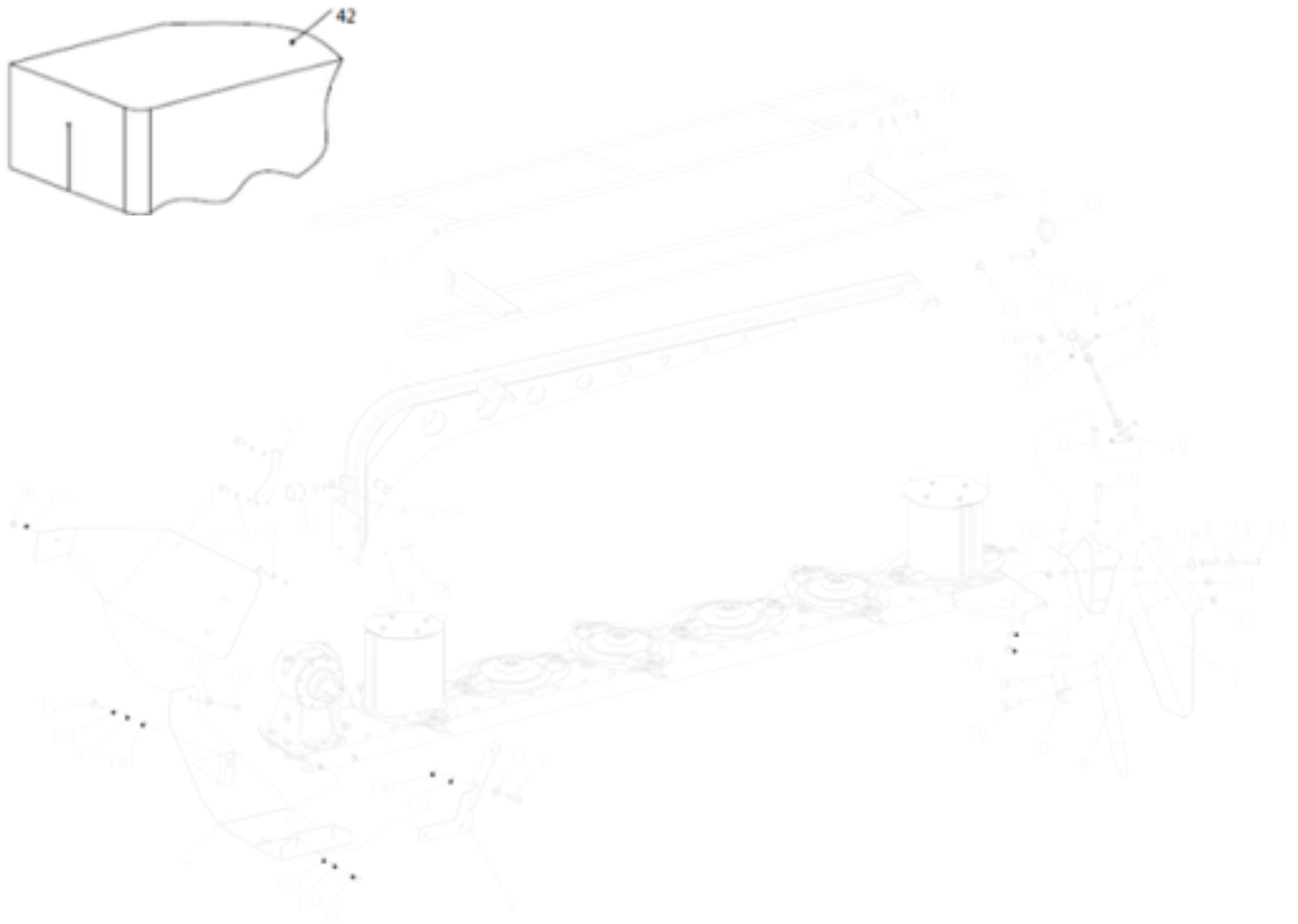

NO.	Code	Designation	Material Code	Qty			
				Mode 170	Mode 210	Mode 250	Mode 290
1	KFDM170.012	Paulin bracket weldment	11000200408	1			
	KFDM215.012		11000200427		1		
	KFDM255.012		11000200433			1	
	KFDM285.013		11000201323				1
2	KFDM170.015	Circular tube bracket 1	12000000808	1			
	KFDM215.015B		11000201169		1		
	KFDM255.012		11000201166			1	
	KFDM285.011		11000201321				1
3	DM170.140	Connecting plate	11000000105		1		
4	DM170.030	Right connecting plate	11000200416		1		
5	DM170.031	Connecting strip weldment	11000200417		1		
6	DM255.033	Connecting plate weldment	11000200436		1		
7	DM170.032	Grass collecting plate weldment	11000200418		1		
8	DM170.143	Compress spring 6*25*48	11010300008		1		
9	DM170.141	Grass connecting rod	11019900020		1		
10	DM170.142	Grass connecting rod base	11000000106		1		
11	GB/T 5783-2000	Bolt M10*25	14010100039		7		
12	GB/T 5783-2000	Bolt M10*40	14010100042		2		
13	GB/T 5783-2000	Bolt M10*35	14010100041		4		
14	GB/T 93-1987	Spring washer 10	14020000007		9		
15	GB/T 95-2002	Flat washer	14040000003		26		
16	GB/T 889.1-2000	Lock nut M10	14050100003		11		
17	GB/T 96.2-2002	Big flat washer 10	14040100003		13		
19	GB/T 5783-2000	Bolt M8*35	14010100021		1		
20	GB/T 5783-2000	Bolt M8*55	14010100025		1		
21	GB/T 889.1-2000	Lock nut M8	14050100002		2		
22	GB/T 5783-2000	Bolt M12*90	14010100081		1		
23	GB/T 96.2-2002	Big flat washer 12	14040100004		2		
24	GB/T 95-2002	Flat washer 12	14040000004		9		
25	GB/T 889.1-2000	Lock nut M12	14050100006		1		

NO.	Code	Designation	Material Code	Qty			
				Mode 170	Mode 210	Mode 250	Mode 290
26	KFDM170.018	Circular tube bracket 2	12000000809	1			
	KFDM215.018B		11000201170		1		
	KFDM255.013		11000201167			1	
	KFDM285.012		11000201322				1
27	DM170.134	Special nut	11000100499		2		
28	GB/T 70.1-2000	Screw M12*30	14060200051		4		
29	GB/T 93-1987	Spring washer 12	14020000008		4		
30		D Lockpin \varnothing 8	11011700016		1		
31	BH7.121	Bumper	11011800063		1		
32	GB/T 5783-2000	Bolt M10*55	14010100045		2		
33	GB/T 5783-2000	Bolt M10*45	14010100043		2		
34	GB/T 5783-2000	Bolt M10*50	14010100044		1		
35	GB/T 41-2000	Locknut M10	14050000003		2		
36	GB/T 5782-2000	Bolt M20*85	14010000045		2		
37	GB/T 889.1-2000	Locknut M20	14050100009		2		
38	KFDM215-116	Connecting bracket-upper	11000000734		1		
39	STB145.037	Adjusting rod	11010500004		1		
40	KFDM215-115	Connecting bracket-Lower	11000000733		1		
41	KFDM215-180	Side plate	11000000622		1		
42	KFDM170.501	Long tarpaulin	11011800097	1			
	KFDM215.501		11011800090		1		
	KFDM255.501		11011800091			1	
	KFDM285.501		11011800113				1

Three Point mounted

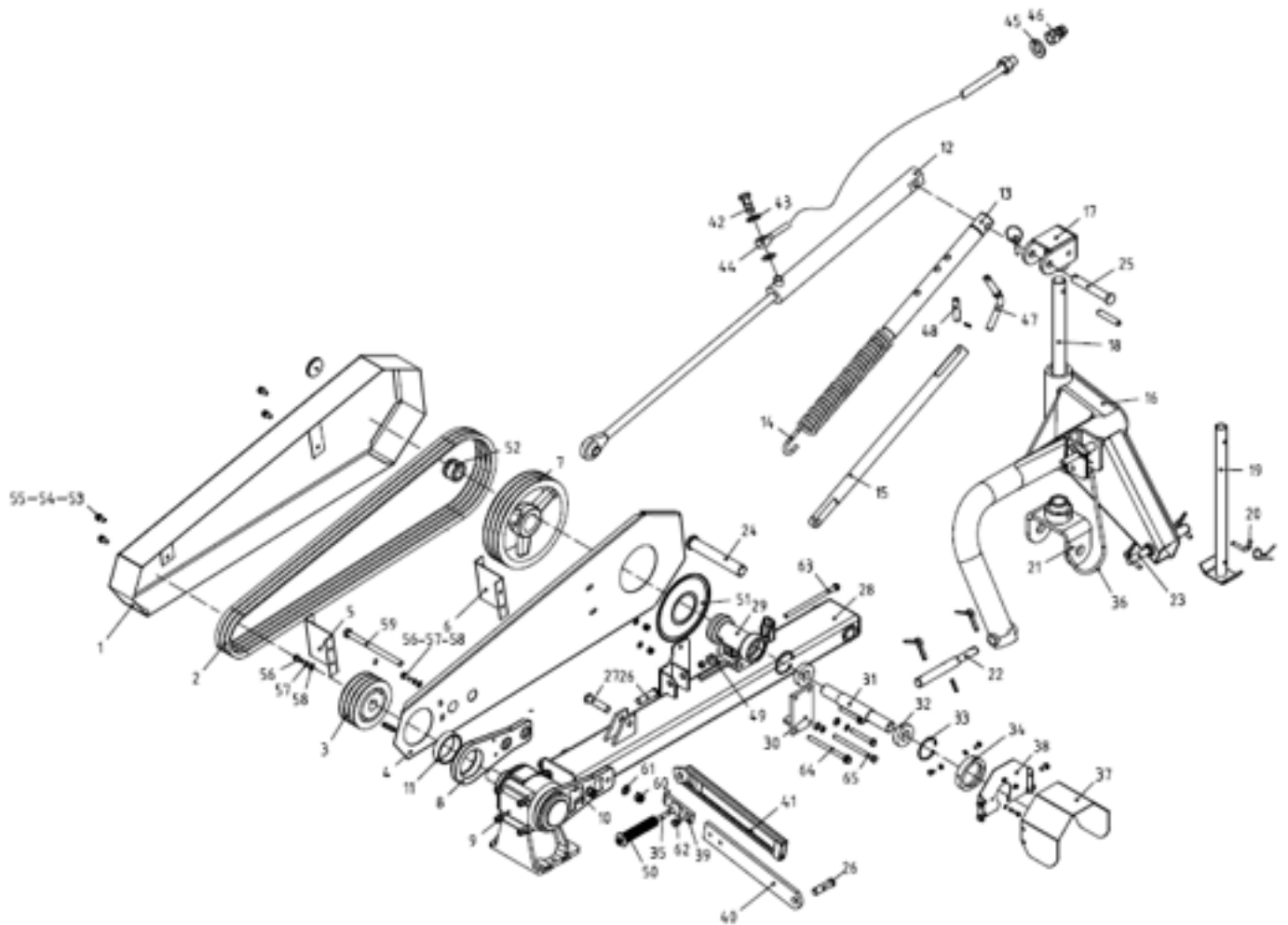

NO.	Code	Designation	Material Code	Qty			
				Model 170	Model 210	Model 250	Model 290
1	DM170.034	Pulley cover weldment	11000200420	1	1		
	DM255.034		11000200437			1	1
2	BX-2641.6	Belt BX-104	11011300027	3	3	4	4
3	DM170.124	Small pulley	11011400007	1	1		
	DM255.102		11011400009			1	1
4	DM170.144	Pulley cover plate	11000000111	1			
5	DM170.024	Right supporting strip weldment	11000200414	1	1		
	DM255.024		11000200434			1	1
6	DM170.025	Left supporting strip weldment	11000200415	1	1		
	DM255.025		11000200435			1	1
7	DM170.121	Big pulley	11011400006	1	1		
	DM255.101		11011400008			1	1
8	DM170.118	Left pivot sleeve	11012900009	1			
9	DM170.019	Gearbox assembly	11000200938	1			
10	DM170.120	Right pivot sleeve	11012900010	1			
11	90*95*26SF-2	Oilless bearing 90*95*26	11011600013	2			
12	NDM215.201	Hydro-cylinder	11011000054	1			
13	KFDM215.014	Floating lever weldment	11000200410	1			
14	NDM215.204	Spring	11010300022	1			
15	KFDM215.114	Floating drawbar	11000100144	1			
16	KFDM215.010	Suspension weldment	11000200406	1			
17	KFDM215.013	Rotating shaft sleeve weldment	11000200409	1			
18	NDM215.112	Main axis of rotation	11000100143	1			
19	NDM215.018	Raker weldment	11000200424	1			
20	DM170.101	L pin	11000100123	1			
21	NDM215.012	Rotating shaft sleeve weldment	11000200421	1			
22	NDM215.111	Left suspension pin	11000100142	1			
23	NDM215.110	Right suspension pin	11000100141	1			
24	NDM215.108	Girder pin	11000100139	1			
25	KFDM215.113	Hydro-cylinder pin	11000100136	1			
26	NDM215.106	Safety pulling plate pin	11000100140	2			
27	NDM215.105	Safety piin	11000100138	1			

NO.	Code	Designation	Material Code	Qty			
				Model 170	Model 210	Model 250	Model 290
28	KFDM215.011	Girder welment	11000200407	1			
29	DM170.122	Big pulley base	11012900011	1			
30	NDM215.021	Pulley base weldment	11000200426	1			
31	DM170.123	Big pulley shaft	11012700012	1			
32	GB/T 276-1994	Bearing 6207-2RS-C3-Z2	11011500024	2			
33	GB/T 893.1-1986	Circlip 72	14000400046	2			
34	DM170.162	Dust guard connect collar	11000100134	1			
35	DM170.148	Double-thread screw of safety device	11000100131	1			
36	BCRI200.126	Hitch	11000000047	1			
37	GSJ165.102	PTO dust cover	11000000113	1			
38	NDM215.116	Bottom mounted plate of dust guard	11000000112	1			
39	DM170.147	Positioning plate	11000000107	1			
40	NDM215.113	Connecting rod of safety device	11000000110	1			
41	NDM215.019	safety rod weldment	11000200425	1			
42	DM170.165	Hollow bolt	11010600003	1			
43	M16	Combined sealing gaskets 16	11011200009	2			
44	NDM215.202	Pipeline assembly	11010700137	1	1		
	NDM255.106		11010700138			1	1
	NDM255.106A		11010700050			1	1
	G1/4		11011200000			2	2
	STU.G1\4		11010900036			1	1
45	BS/ A21.50(G1/2)	Combined sealing gaskets G1/2	11011200003	1			
46	G1\2	Quick connector	11010900020	1			
47	NDM215.115	Floating quick pin	11000100145	1			
48	NDM215.103	Floating pin	11000100137	1			
49	DM170.119	Tetragonal nut M12	11000100128	1			
50	M12 (29*13*3)	Butterfly spring(29*13*3)	11010300000	36			
51	DM170.145	Pulley annular plate	11000000114	1			
52	Z3A-35*60	Swelling link sets 35*60*45	11011900001	1			
53	GB/T 5783-2000	Bolt M10*25	14010100039	8			

NO.	Code	Designation	Material Code	Qty			
				Model 170	Model 210	Model 250	Model 290
54	GB/T 95-2002	Flat washer 10	14040000003	8			
55	GB/T 93-1987	Spring washer 10	14020000007	8			
56	GB/T 5783-2000	Bolt M12*35	14010100069	1			
57	GB/T 93-1987	Spring washer 12	14020000008	1			
58	GB/T 96.2-2002	Big flat washer 12	14040100004	1			
59	GB/T 5783-2000	Bolt M16*230	14010100105	2			
60	GB/T 889.1-2000	Lock nut M16	14050100008	2			
61	GB/T 95-2002	Flat washer 16	14040000006	2			
62	DM170.151	Dowel pin	11000100133	1			
63	GB/T 5783-2000	Bolt M12*220	14010100063	1			
64	GB/T 5783-2000	Bolt M12*170	14010100061	2			
65	GB/T 5783-2000	Bolt M12*90	14010100081	2			